

Advanced Anytime Control Algorithms and Modeling of Turbojet Engines

***Ladislav Fózó, **Rudolf Andoga, *Ladislav Madarász**

* Department of cybernetics and artificial intelligence FEI TU Košice, Letná 9, Košice, 04001; ladislav.fozo@tuke.sk, ladislav.madarasz@tuke.sk

** Department of avionics, LF TU Košice, Rampová 7, Košice 04001; rudolf.andoga@tuke.sk

Abstract: Advances in control the aircraft engines achieve state, in those dominating factors are the demands for safety, quality and efficiency. Among the growing complexity of present systems, it is necessary to project such systems, as well as progressive methods of control, which increase effectiveness of their operation, increase safety and at the same time reducing their cost. One of the efficient approaches in this area is also the area of Anytime Control Algorithms, which offers possibilities, so that the controlled system would flexibly react to changes of outer environment and could survive deficiency of processing time, data and resources. These algorithms can be possibly defined as a sort of trade-off in processor (deliberation) time for quality of results. Moreover we present the base of analytic modeling of small turbojet engine MPM-20 with application of anytime control algorithms on its base.

Keywords: turbojet engine, small turbojet engine, anytime control, artificial intelligence, analytic modeling

1 Small Turbojet Engine – MPM 20 as an Object of Modeling and Control

The experimental engine MPM 20 has been derived from the TS – 20 engine, what is a turbo-starter turbo-shaft engine previously used for starting engines AL-7F. The engine has been adapted according to [10]. The engine has been rebuilt to a state, where it represents a single stream engine with radial compressor and single one stage non-cooled turbine and outlet jet. The basic scheme of the engine is shown in the Figure 1.

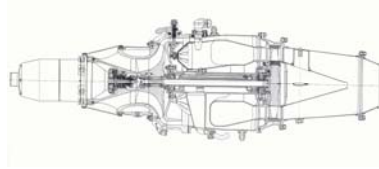

Figure 1
The scheme of MPM 20 engine [10]

In order to model the engine, it is necessary to measure its characteristics. All sensors, except fuel flow and rotations sensor, are in fact analogue which in and have voltage output. This is then digitalized by a SCXI measurement system and corresponding A/D converter and sent through a bus into computer. Every parameter is measured at the sampling rate of 10 Hz. The data acquisition has been done in LabView environment [4]. The digital measurement of parameters of MPM 20 engine in real time is important to create a model and control systems complying with FADEC definition („Full Authority Digital Electronic Engine Control“). Moreover we needed to change the engine from static single regime engine into a dynamic object, what was done by regulation of pressure beyond the compressor according to which the current fuel supply actuator changes actual fuel supply for the engine in real time. The system has been described in [7]. The graph in figure 2 shows dynamic changes of parameters of the engine to changes of fuel supply input.

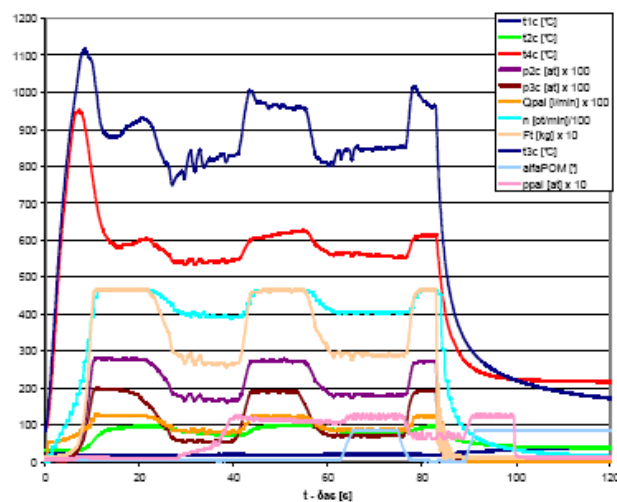

Figure 2
The measured data by indirect regulation

2 Modeling the MPM 20 Turbojet Engine

Static and dynamic properties of turbojet engines (MPM 20) can also be described by a mathematical model of operation single stream engine under equilibrium or non-equilibrium conditions. This will allow to model thrust, fuel consumption, pressures and temperatures of the engine by different altitudes and velocities in the chosen cuts of the engine.

The steady operation of the engine is such a regime, where in every element of the engine same thermodynamic processes are realized. Operation of an engine in its steady operation can be described by:

- 1 algebraic equations of balance of mass flow of working materials through nodes of the engine, equations of output balance, equations of regulation rules and equations describing particular oddities of an engine. A system of equations expresses that for given outer conditions of operation of an engine, characteristics of all nodes of an engines and preset values of control parameters (fuel supply, cross section of the output nozzle, angle of compressor blades), operation of the engine will settle itself on one and only one regime [18]
- 2 graphically, by utilization of knowledge of characteristics of all parts (output, compressor, turbine, etc) of the engine and their preset curves of joint operations (e.g. lines of stable rations of T_{3c}/T_{1c} in compressor). Designation of all curves of the engine is done in a way that we will try to fulfill continuity conditions for all parts of the engine and characteristics of all these parts are given. These characteristics can be found by direct measurement, computation, etc.

Any regime of the turbojet engine has to fulfill the continuity equation which designates dependencies between mass flow of air through the compressor, turbine, combustion chamber and exhaust system:

$$Q_{vs} = Q_k = Q_{sk} = Q_T = Q_r = Q \quad (1)$$

and a condition of no distortion of the shaft

$$n_k = n_T = n \quad (2)$$

where

- Q_{vs} – mass flow of air through input system,
- Q_k – mass flow of air through the compressor
- Q_{sk} – mass flow of air through combustion chamber,
- Q_T – mass flow of gases through the turbine,

- Q_{tr} – mass flow of gases through exhaust nozzle,
 n_k – revolutions of compressor,
 n_T – revolutions of turbine.

Another condition for steady operation of the engine has to be fulfilled – the engine doesn't change its revolutions in time.

$$\frac{dn}{dt} = 0 \quad (3)$$

This condition will be fulfilled when output of the turbine will be the same as output taken by the compressor and accessories of the engine

$$W_{KC} = \eta_m W_{TC} \quad (4)$$

where

- η_m – mechanical effectiveness of the engine,
 W_{KC} – technical work of the compressor,
 W_{TC} – technical work of the turbine.

A detailed algorithm of designation of operational points of steady operation of a single stream engine is described in [18].

Non steady operation of an engine is a regime of its operation, where in every element of the engine time changing thermodynamic processes occur. Function of the engine in such non steady regimes can be described by a system of differential and algebraic equations. Such system of equations describes transient processes by change of regime of the engine, when thrust lever is moved or other change of flight regime occurs.

Such non-steady regime occurs when work of the turbine and compressor isn't equal, this means that rotation moments of the turbine M_T and compressor M_K aren't equal. Acceleration of the engine is dependant upon this difference:

$$M_T - M_K - M_{ag} = J \frac{d\omega}{dt} \quad (5)$$

where

- $\frac{d\omega}{dt}$ - angular acceleration of the engine,
 J - moment of inertia of all rotating masses reduced to the shaft of the engine
 M_{ag} - moment needed for actuation of aggregates and overcoming of friction.

As the angular velocity is given by the equation $\omega = \frac{\pi n}{30}$ and output is given by equation $P = M\omega$ and incursion of mechanical effectiveness, the basic equation of non-stable operation of the engine is obtained:

$$P_T \eta_m - P_k = J \frac{\pi^2}{900} n \frac{dn}{dt} \quad (6)$$

Stable operation of the engine is then computed which gives the initial conditions. Differences of revolutions are then computed in a given time space Δt and we repeat this algorithm until the end of the transient process.

Analytic mathematical model of the engine is based on physical rules which characterize properties and operation of different nodes of the engine, thermodynamic and aerodynamic processes obtained by temperature cycle. While we have to take in account range of operation of turbojet engines which give changes of thermodynamic properties of working material.

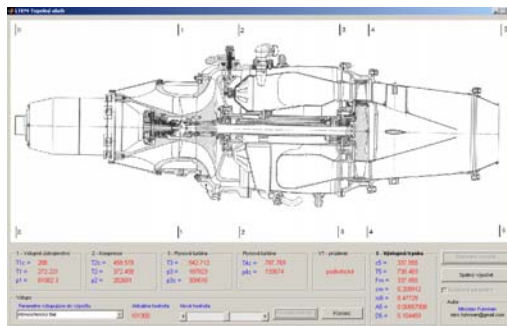

Figure 3

Temperature circuit calculation worked out in Matlab GUI

Contrary to the experimental one, the analytical model of the engine allows us to compute parameters of the engine that cannot be simply simulated by models built upon the experimental data, which use only known parameters. This way we can compute engine surge lines, workloads on shafts, different internal temperatures and also parameters, which are measured and can be used for checking the results of the model. The analytic model allows us to compute parameters of our engine also by different values of outer pressure and temperature of air, different speed of flight and height [13]. Complexity of the model is out of scope of this paper, figure 4 illustrates computed curve of steady state of operation for the MPM 20 engine. X-axis denotes the air flow through the engine, Y-axis the compression ratio, red line represents surge line, green lines represent different speed (reduced RPM's), and the dark red line represents acceleration of the engine with fast geometry of the exhaust nozzle.

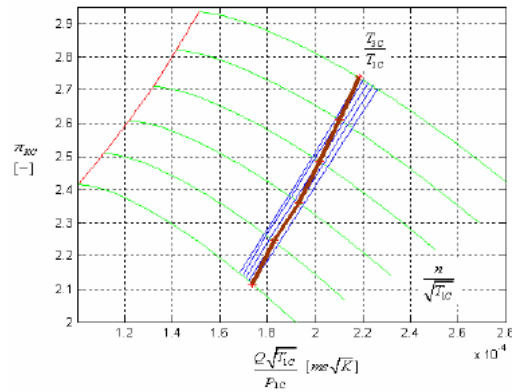

Figure 4

The curve of steady state of operation of the MPM 20

3 Advanced Anytime Control Algorithms of Turbojet Engines

Our main global aim is to increase safety and in second term the efficiency of operation in terms of design of new methods of control and their testing on our experimental engine.

The anytime control algorithm is a further development of situational control algorithm as described in [1, 2, 3, 4]. The situational control algorithm is to be expanded with another situational frame S_3 dealing with:

- errors in input sampling, because of overload of the measurement/control system or error of the system itself,
- errors of measurement devices or information channels,
- deficiency of input data in general.

By design and implementation of the architecture of anytime control algorithm into situational control algorithm, we have used the structural scheme of formatter control [11, 16] and a global algorithm of situational control as described in [4, 5], which is further expanded by one situational frame and therefore one strategy of control. Figure 5 shows the scheme of situational control algorithm with implemented contractual anytime algorithm, grey fields denote atypical situational frames. For control design purposes the following situational frames have been proposed:

- S₁ – start-up of the engine:
 - S_{1,1} – overshoot of limit temperature T_{4C} by start-up,
 - S_{1,2} – deficient compression p_{2C} by startup.
- S₂ – stable regime of operation:
 - S_{2,1} – atypical states:
 - S_{2,1,1} – overshoot of limit temperatures T_{4C},
 - S_{2,1,2} – permanent deficiency in fuel supply,
 - S_{2,1,3} – unstable speed,
 - S_{2,2} – acceleration of the engine,
 - S_{2,3} – deceleration of the engine.

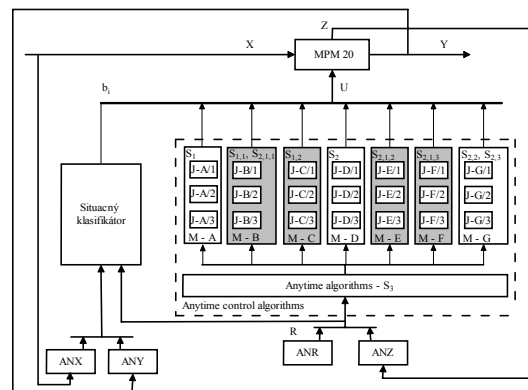

Figure 5

Scheme of situational control algorithm with contract anytime control algorithm

The algorithm of control in case of a special situation S₃ (Fig. 5, anytime algorithm block anytime algorithm – S₃), can be realized by different approaches. The simplest one is to change the input sample rate. Regarding the precision, this approach is not sufficient. The other approach is to create a system of prediction of missing samples (mathematical, statistical approximation models, or predictive models usable for multiple step prediction with fast horizon, etc.). [6] We use an analytical model of the MPM 20 engine for this purpose.

The anytime control algorithm block – S₃, will include the mathematical model of steady and non/steady operation of the engine, which will cooperate with situational classifier that will indicate if the situation S₃ has occurred or not. If the situation has occurred the parameters obtained from model will be used to supply or replace actually missing data from parameter. This is one of the purposes of anytime control algorithm.

The second task is to expand the situational classifier designed in [4], which will include also an expert system to deal with sub/situations of anytime control algorithm. Every situation has a module designated as M and a letter according to its order (the first module has A). Every module has also three elements, which for the given situational frame represent three different regulators. By implementation of the quality function, we can select which type of control (or combination) will be used. If the situation S_3 hasn't occurred, the situational classifier will be used to obtain the maximal quality.

The units shown on figure 5 from A/1 to J – G/1 represent regulators with control parameter Q_{pal} (fuel supply), units A/2 to G/2 are regulators with control parameter D_5 (diameter of the output nozzle) and units A/3 to G/3 have control systems with two parameters, where one control parameter is fuel supply and the second control parameter is diameter of the outlet nozzle, for individual atypical states of MPM 20. The further part will show results from simulations:

- Constant control and thrust regulator (unit - D/1), that means maintenance of stable operation of the engine (situation S_2), (backup – mechanical system of regulation);
- control to selected speed and thrust (selected operational state of the engine), that means acceleration (situation $S_{2,2}$) or deceleration (situation $S_{2,3}$), with use of these units:
 - unit G/1, in this case $D_5 = \text{const.}$,
 - unit G/2, in this case the temperature T_{3C} will be maintained on a constant level, or
 - unit G/3 to obtain maximal thrust of the engine, by maximal speed of the engine

By all designed control units, limits of all parameters will be checked.

As the parameters that will represent quality of any designed algorithm (and of the control of the whole process), thrust of the engine F_b , specific fuel consumption c_m , or combination of both can be selected.

Constant speed regulator of MPM20

Constant speed regulator secures that by incursion of disturbances in engine's steady state of operation, the speed of the engine won't change or will change only in a desired interval. Figure 6 shows an example of regulation to a desired value and in time of 6 seconds a disturbance occurs, regulator returns the speed of the engine into desired level of about 46100 rpm [rotations per minute].

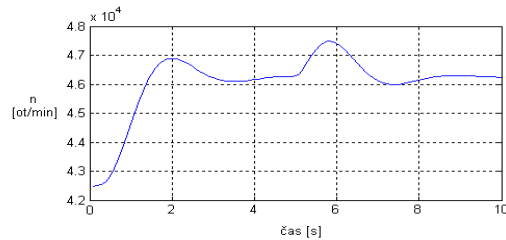

Figure 6

Simulated operation of the constant speed regulator

Regulator of desired speed of the MPM 20 engine

As can be seen in the figure 6, the regulator of constant speed can be used in a simple manner also as an acceleration or deceleration automat, while the desired speed is given directly or computed from the position of throttle lever.

However, if the designed analytical steady/non steady state of operation model of the engine will be expanded by a further algebraic equation, law of regulation of the engine by exhaust nozzle diameter, we will obtain an analytic model of steady and non/steady operation of the engine with variable exhaust nozzle geometry (diameter).

Figure 7 shows curves of non/steady operation of the engine (acceleration) with variable exhaust nozzle geometry. The curves have been obtained by changing the cross/section of the exhaust nozzle. Blue line represents the acceleration to the smallest cross/section of the exhaust nozzle and red one, acceleration with the engine opening to the biggest cross/section of the exhaust nozzle. This regulator by use of the control unit G/2 and regulation to desired speed and thrust will keep the temperature T_{3C} on a constant level.

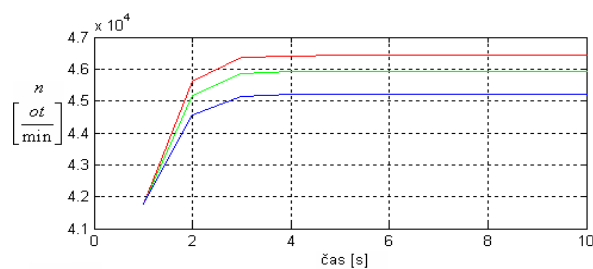

Figure 7

Acceleration by change of exhaust nozzle cross/section

In case of different setting of the exhaust nozzle, an infinite number of steady curves of the engine exists. However the area is limited by maximal speed, maximal temperature T_{3C} and curve were jamming of compressor occurs or the cross/section is maximal.

Regulator of maximal thrust of the engine

Achievement of the maximal thrust of the engine, by set speed with use of control unit G/3 can be obtained either by acceleration to maximal speed by fuel supply or by onset of maximal cross/section of the exhaust nozzle and further decreasing of the cross/section. This control algorithm will be applied if the parameter representing the quality of control is the thrust of the engine. The thrust will be at first increased by acceleration and further by regulation of the exhaust nozzle cross/section. The performance profile in time of acceleration will be a function of speed of the engine $F_T=f(n)$ and after achievement of maximal speed it will be a function of exhaust diameter $F_T=f(D_5)$.

Figure 8 shows steady state of operation of the engine with variable output geometry. It shows that by opening of the exhaust nozzle (orange curve), the curve of steady operation of the engine will move further from the surge line (the red line), also temperature T_{3C} is lower and therefore the final increase in this temperature is higher than in an engine with fast geometry, thus we can accelerate faster.

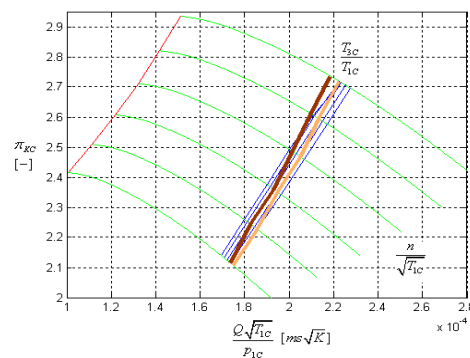

Figure 8

Steady state of operation with variable exhaust nozzle geometry

The results show that by use of regulator of maximal thrust, we have to use two control strategies. At first to set the maximal diameter of the exhaust nozzle to achieve maximal speed of the engine (and faster acceleration) and then by decreasing the exhaust nozzle cross/section we obtain the maximal thrust of the engine MPM 20.

Conclusions

Modular structure of contractual anytime control algorithms allows us to satisfy increasing demands on the quality of control. The system consists of different units, which incorporate different strategies of control or different complexity. If there will be any limits (deficiency of time, information, resources), only the units will be used that will secure maximal utility of the system.

The developed analytic model and further simulations, we have come to a conclusion that by regulation of the engine by fuel supply, also regulation of exhaust nozzle cross/section plays an important role. And that from the viewpoint of increasing in efficiency of the engine or increasing the safety regardless of operational state of the engine, which represents a key element in the mechatronic complex of an aircraft.

Acknowledgement

The work described in this paper has been supported by VEGA num. 1/0394/08 „Algorithms of situational control and modeling of complex systems“.

References

- [1] Andoga, R., Főző, L., Madarász, L.: Approaches of Artificial Intelligence in Modeling and Control of a Small Turbojet Engine, Proceedings of the microCAD 2007 International Scientific Conference, March 22-23, 2007, University of Miskolc, Hungary, pp. 1-6, ISBN 978-963-661-742-4
- [2] Andoga, R., Főző, L., Raček, M., Madarász, L.: Inteligentné metódy modelovania a riadenia zložitých systémov, Medzinárodná konferencia Kybernetika a informatika, 28.-30. jún 2006, Michalovce, Slovenská republika, ISBN 80-227-2431-9, pp. 77-78
- [3] Andoga, R., Madarász, L., Főző, L.: Situational Modeling and Control of a Small Turbojet Engine MPM20, IEEE International Conference on Computational Cybernetics, August 20-22, 2006, Tallin, Estonia, ISBN 1-4244-0071-6, pp. 81-85
- [4] Andoga, R.: Hybridné metódy situačného riadenia zložitých systémov., Doktorandská dizertačná práca, FEI TUKE, 2006, p. 120
- [5] Andoga, R.: Hybridné prístupy v situačnom riadení zložitých systémov., Písomná práca k dizertačnej skúške, FEI TUKE, 2005, p. 66
- [6] Babinec, S.: Metódy UI v predikcii časových radov, Diplomová práca, FEI TU Košice, 70 pp., 2003
- [7] Főző, L., Andoga, R., Madarász, L.: Digital Control System for MPM20 Engine. In: ICC 2007: 5th IEEE International Conference on Computational Cybernetics, Gammarth, Tunisia, October 19-20, 2007, Proceedings pp. 281-284, ISBN 1-4244-1146-7
- [8] Hocko, M.: Hodnotenie stavu LTKM na základe zmeny termodynamických parametrov., Dizertačná práca, VLA M.R.Š. Košice, 2003
- [9] Horvitz, E. J., Suermondt, H. J., Cooper, G. F.: Bounded Conditioning: Flexible Inference for Decision under Scarce Resources. In Proceedings of the 1989 Workshop on Uncertainty in Artificial Intelligence, 182-193. New York: North-Holland, 1989

- [10] Lazar, T., et. al.: Tendencie vývoja a modelovania avionických systémov, 160 pp, ISBN 80-88842-26-3, MoSR, Bratislava, 2000
- [11] Madarász, L.: Formátorové a situačné riadenie komplexov. Automatizace 29/3, pp. 76-80, Praha, 1986
- [12] Madarász, L.: Inteligentné technológie a ich aplikácie v zložitých systémoch. Vydavateľstvo Elfa, s.r.o., TU Košice, 349 pp., ISBN 80 – 89066 – 75 - 5, 2004
- [13] Považan J.: Konštrukcia matematických modelov leteckých turbo-kompresorových motorov, VLA M.R.Š. v Košiciach, 1999, ISBN 80-7166-030-2
- [14] Sarnovský, J., a kol., Riadenie zložitých systémov. Alfa Bratislava, ISBN 80-05-00945-3, 384 pp., 1992
- [15] Takács, O., Várkonyi – Kóczy, A. R.: Szoft számítási eszközök anytime rendszerekben., Híradás-technika 2001/2 május, Volume LVI., pp. 55-59., Takács, O.: Eljárások és hibakorlátok lágy szá-mítási módszerek anytime rendszerekben való alkalmazásához., Doktori (PhD) értekezés, BME Budapest, 2004
- [16] Várkonyi – Kóczy, A., Kováčsházy, T.: Anytime Algorithms in Embedded Signal Processing Sys-tems. IX. European Signal Processing Conf., EUSIPCO-98, Rhodos, Greece, Sept. 8.-11, Vol. I, pp. 169-172., 1998
- [17] Zilberstein, S.: Operational Rationality through Dompilation of Anytime Algorithms. Dissertation for the degree of doctor of philosophy in computer science, 1993
- [18] Zilberstein, S.: Using Anytime Algorithms in Inteligent Systems. AI Magazine, 17(3):73-83, 1996