

## Case Studies in Teaching Fuzzy and Advanced Control Strategies

**Stefan Preitl<sup>1</sup>, Radu-Emil Precup<sup>1</sup> and Zsuzsa Preitl<sup>1,2\*</sup>**

<sup>1</sup> “Politehnica” University of Timisoara, Dept. of Automation and Appl. Inform.  
Bd. V. Parvan 2, RO-300223 Timisoara, Romania  
Phone: +40-256-4032-29, -30, -24, -26, Fax: +40-256-403214  
E-mail: stefan.preitl@aut.upt.ro, radu.precup@aut.upt.ro

<sup>2</sup> Budapest Univ. of Technology and Economics, Dept. of Transport Automation  
Műegyetem rkp. 3. Bldg K. I.15, Budapest, Hungary  
Phone: +40-256-4032-29, -30, -24, -26, Fax: +40-256-403214  
E-mail: preitl@sch.bme.hu

*Abstract: The teaching of fuzzy and advanced control strategies at bachelor level is correlated with the usually heuristic means of fuzzy control, incorporating human skills, the drawback being in the lack of general-purpose development methods. A major problem, which follows from the study of advanced control strategies is the understanding of its background the basic development methods and some applications. The paper, organized in two parts, present control algorithms exemplified on four case studies in teaching Advanced Control Engineering courses: temperature control, level control in a one-tank system, speed control and position for an inverted pendulum. PI(D) control (based on ESO-m and 2p-SO-m tuning criterions), Internal Model Control (IMC) Smith-predictor and Fuzzy control strategies are presented underlining the problem of bump transfer when switching between manual and automatic modes or between two controllers occurs. Also a Generalized Predictive Control (GPC) strategy is presented and combined with static linearization using the inverse static characteristics of the plant. The case studies presented here are assisted by laboratory experiments. The case studies concerning fuzzy controlled servo-systems, accompanied by digital simulation results and real-time experimental results, validate the presented methods.*

*Keywords: control strategies, PI(D) control, fuzzy control, IMC and GPC strategies, bumpless transfer*

---

\* Zsuzsa Preitl was teaching assistant at “Politehnica” University of Timisoara in the academic year 2004-2005 and she participated in the development of laboratory activities.

## 1 Introduction

Advanced control strategies include different types of control strategies and algorithms. In order to make them more accessible for the students it is necessary to be able to implement and somehow compare algorithms, if possible on a real, complex system. The main algorithms which are presented incorporate various design techniques: dedicated PI(D) control with bumpless transfer, Internal Model Control (IMC), Generalized Predictive Control (GPC) and fuzzy control, implemented as laboratory applications. The plants taken into consideration are dedicated laboratory equipments: the DC drive systems (with DC generator as load) as representative for rapid plants and the temperature control system in two applications illustrating slow plants, and the inverted pendulum as unstable plant.

The case studies represent laboratory applications in Control Engineering and Advanced Control Engineering lectures [1, 2]. Each control structure presented is discussed as technical application.

First the aim of the case study is presented; then the plant working principles and its models are presented and some identification aspects of the system parameters are briefly introduced. Since all applications are nonlinear their static characteristics are calculated taking into account the physical limitations. For each application minimum two control strategies are imposed for analysis and implementation. Finally, laboratory experiments and/or simulations decide the students to accept one or other control solution.

Special problems such as bumpless transfer with PI(D) control, applications of GPC and extensions to fuzzy controller development, are emphasized and must be discussed for a higher evaluation. In order to develop the team-working spirit, all applications are solved by teams consisting of 3 (2) students with identical motivation.

The paper is structured in four Chapters. Chapters 2 and 3 treat separately one case study, and Chapter 4 finalize it by conclusions.

## 2 First Case Study: DC Drive System (Rapid Plant)

The system studied in this chapter is a classical drive system application with DC-motor (DC-m) loaded by a DC generator (DC-g) with variable controllable load. Two laboratory setups exist for this application:

- the AMIRA-DR300 DC-m-DC-g drive [3],
- the A2 computer-controlled application.

The subjects studied by each team are grouped in the following phases: mathematical modelling; definition of control aims; steady-state calculations for regimes imposed by the teacher; development of control structures at the level of DC-m; algorithmic design of controllers; digital simulation of solutions obtained as result of development; laboratory experiments related to the control systems, two from three solutions developed; conclusions and recommendations concerning possibilities to use the systems investigated. Because the systems are implemented digitally, the comparison of experimental results with the simulation ones is done relatively easily.

## 2.1 System Structure. Mathematical Modelling

The application 1 represented by the DR-300 drive system structure [3], consists of two sub-systems, M1 - the DC-motor (DC-m) and M2 - the DC generator (DC-g), subject to decoupling (in modelling). The DC-g sub-system represents the load for the drive system. The physical coupling between the two sub-systems allows also mechanical extensions to ensure the modification of total inertia moment,  $J_{tot}$ .

The two sub-systems are modelled in decoupled version. For example, the nonlinear state-space model is given by (1):

$$\begin{aligned}
 \dot{x}_1 &= -\frac{1}{T_{ex}} \cdot x_1 + \frac{1}{T_{ex}} \cdot \frac{1}{R_{ex}} \cdot u_{ex}, \\
 \dot{x}_2 &= -\frac{1}{T_G} \cdot x_2 + \frac{1}{T_G} \cdot \frac{1}{R_G} \cdot x_2 \cdot r_s + \frac{1}{T_G} \cdot \frac{1}{R_G} \cdot k_\omega \cdot x_1 \cdot x_3, \\
 \dot{x}_3 &= -\frac{1}{J_{tot}} \cdot k_\omega \cdot x_1 \cdot x_2 + \frac{1}{J_{tot}} \cdot k_m \cdot x_4, \\
 \dot{x}_4 &= -\frac{1}{T_a} \cdot x_4 - \frac{1}{T_a} \cdot \frac{1}{R_a} \cdot k_e \cdot x_3 + \frac{1}{T_a} \cdot \frac{1}{R_a} \cdot u_a, \\
 u_G &= x_2 \cdot r_s, \quad \omega = x_3, \quad i_a = x_4, \quad P_G = k_\omega \cdot x_2 \cdot x_3.
 \end{aligned} \tag{1}$$

The following variables and parameters of the controlled plant are used in (1): state variables:  $x_1 = i_{ex}$ ,  $x_2 = i_G$ ,  $x_3 = \omega$ ,  $x_4 = i_a$ , input variables:  $u_a$  - armature voltage of DC-m,  $u_{ex}$  - excitation voltage of DC-m (in particular, it is constant),  $r_s$  - load resistance of DC-g (this represents a disturbance), output variables:  $u_G$  - armature voltage of DC-g,  $\omega$  - angular speed at of drive shaft,  $P_G$  - electrical power of DC-g,  $i_a$  - armature current of DC-m, electrical time constants:

$$T_G = \frac{L_G}{R_G}, \quad T_a = \frac{L_a}{R_a}, \quad T_{ex} = \frac{L_{ex}}{R_{ex}}.$$

Linearizing (1) the corresponding linearized informational bloc diagram is presented in Fig. 1. The linearized state-space model can be derived from it.

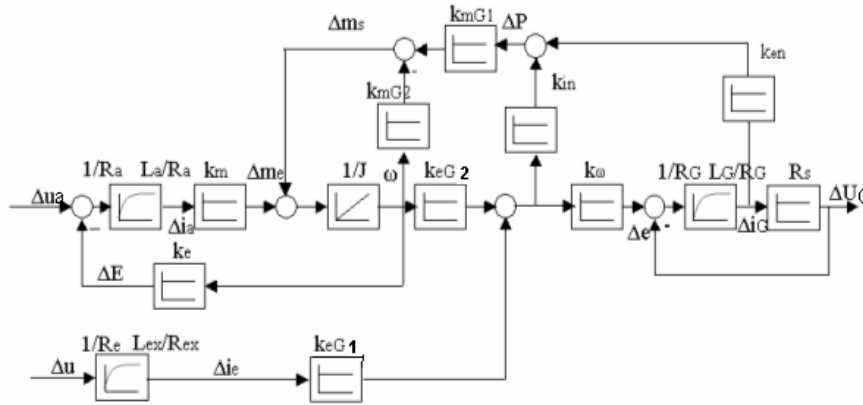

Figure 1  
 DC-motor-DC-generator drive system: nonlinear (a) and linearized (b) block diagrams

The time spent for one application is of 4 hours (on two weeks with one weak break). The authors consider that it is very important that each phase should be accompanied by the final conclusions relative to the most advantageous control solution.

The application 2 is employed in a microcontroller and computer-aided speed control of a DC-m-DC-g drive system; the structure presented in Fig. 2. The parameters characterizing the mathematical model can be determined either on the basis of catalogue data (in case of application 1) or by experimental identification, as continuous-time reduced order model of benchmark type (PL2); the data are processed in computer-aided manner (in case of application 1 and 2).

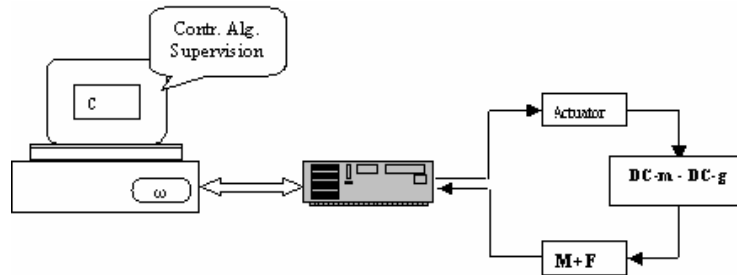

Figure 2  
 Structure of DC-m-DC-g drive system

## 2.2 Control Structures and Algorithms

As first step in the development of the control system (CS) the control aims must be defined, by using empirical quality indices  $\{t_s, t_1, \sigma_1, \text{static coefficient } \gamma_n\}$ . For

theoretical analyses the frequency response functions must be interpreted, too, this is the case of  $L(j\omega)$ ,  $S(j\omega)$ ,  $T(j\omega)$  with the known nomenclature according to [4].

The following control structures can be employed for the DC-m-DC-g drive system: open-loop CS without/with disturbance compensation, without/with dynamic compensator; CS as conventional (feedback) control loop as function of the speed (in case of both applications), with controller tuned in terms of an optimum method [4]: the Modulus Optimum and the Symmetrical Optimum methods, in two parameterized versions [5, 6]; cascade CS, with two control loops as function of the current (with internal I controller) and the speed (only for the DR-300 application), with controller tuned by an optimum method; state-feedback CSs. Advanced students can develop the version with state-feedback estimator; The structure is then included to an external loop that ensures zero steady-state control error. The development steps are backed up by the mentioned lecture notes and must be associated by comments together besides the presentation of experimental and simulation results performed.

The algorithmic calculus of control laws must be finalized by the students in forms that should be subject to implementation. Several implementation versions are of interest, the student having access to a certain controller type and implementation version and modifying the controller parameters  $\{p$  - controller parameters,  $h$  - sampling period, the access to limitations $\}$ . Fig. 3 shows implementation versions of a PID algorithm with AWR measure included (for the PI algorithm  $k_d = 0$  must be introduced).

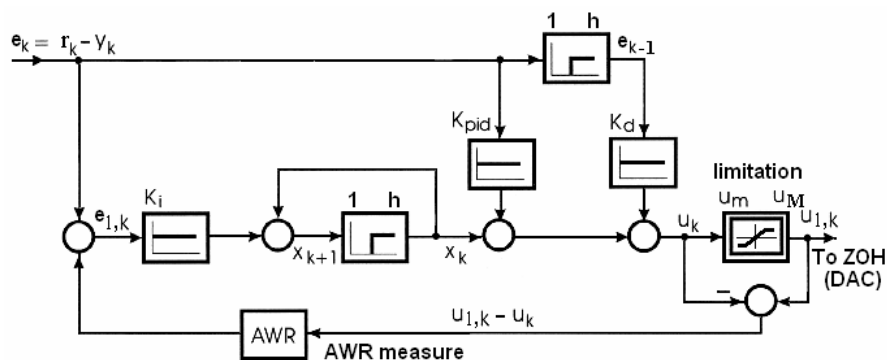

Figure 3  
 Informational block diagram of PID algorithm with AWR measure

### 2.3 Control Monitoring

Both applications are monitored in distinct manner because the user interfaces have been constructed separately. From a didactical point of view it is of interest to monitor the application 2, Fig. 4, where the students have operational access. In

this case the students may follow the effects of bumpless transfer from one control algorithm to another one; Fig. 4 illustrates also the recorded experiments. Fig. 5 highlights one of the Simulink diagrams employed in the simulation of the dynamic behaviour of the DC-m-DC-g; the drive system has a single control loop (speed control) and DC-g is equipped with its own voltage control loop.

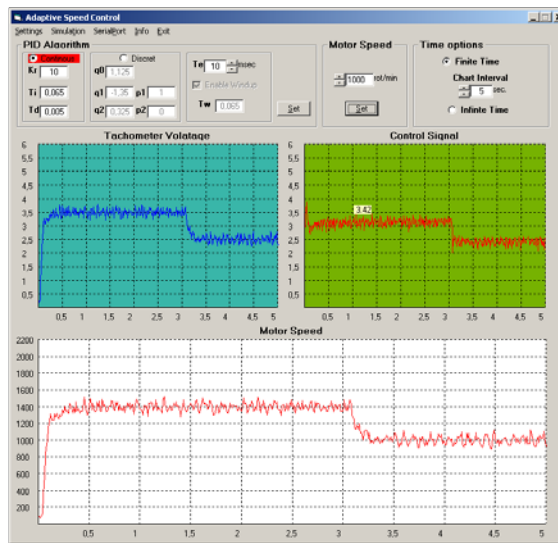

Figure 4  
 Control monitoring (application 2)

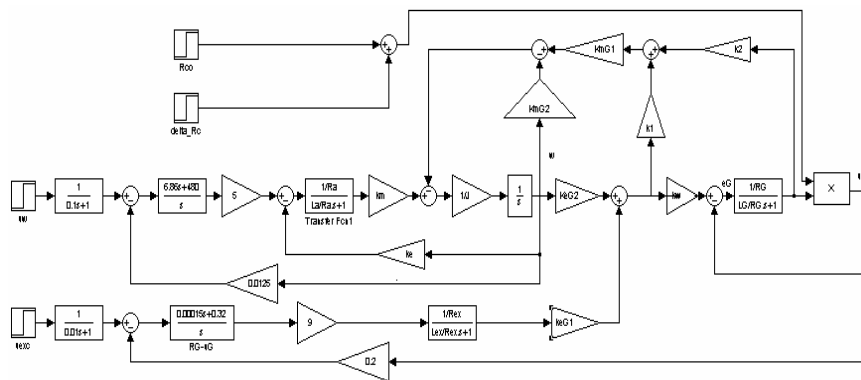

Figure 5  
 Simulink diagram for modelling the control system of DC-m-DC-g

Personal conclusions should be focused on the comparison of different control solutions from the point of view of performance achieved. They can tackle also the recommendation of a certain control solution.

### 3 Second Case Study: Temperature Control System (Slow Plant)

Slow processes, characterized by large time constants of tens of seconds and often with dead time, can be modelled exactly relatively difficult [7, 8]. Therefore the case study is concentrated on two aspects:

- a minimum theoretical mathematical modelling, accompanied by the treatment of some diagrams, followed by the development of some simulated control applications,
- an applicative part, related to laboratory equipment, where the experimental identification method is employed (response to step signal).

For the sake of learning the techniques for the development of specific control solutions the laboratory activities are done on two specific plants: the model of a room, pre-heated by long pipelines; the control solution is microprocessor-assisted; the model of a room, with floor-based heating; the control solution is computer-assisted. The first plant is modelled also analytically. In order to determine the parameters the plants are then experimentally identified using input-output data. This represents the basis for the development and analysis of different control structures and for the calculation of controllers having adequate properties.

The following control solutions may be studied (adapted to the limits offered by all equipment): open-loop control without and with compensation for disturbances, without and with serial dynamic compensation; PI control with the controlled tuned in terms of using the experimental model; control structures with Smith predictor and dead-beat control in Dahlin's version; model-based predictive control based on the discretized model of controlled plant.

The application 1, namely laboratory model of a room heated by a long pipeline, is built according to Fig. 6. The temperature sensor (TS) can be placed in three distinct places and this increases the flexibility of the model to be used:

- for the TS placed in the positions 1 or 2, PL1-DT models are used,  $T_m \gg T_1$ :

$$H_p(s) = \frac{k_p}{1 + s \cdot T_1} e^{-s \cdot T_m}, \quad (2)$$

- for the TS placed in the position 3, PL2-Tm-DT models can be used:

$$H_p(s) = \frac{k_{p_3}}{(1 + s \cdot T_1)(1 + s \cdot T_2)} e^{-s \cdot T_m}. \quad (3)$$

The parameters characterizing the models are determined experimentally for a certain temperature domain, for example 50-70 °C, Fig. 7. Taking into account the scaling of several elements, the final transfer function will have the form (4):

$$H_p(s) = \frac{0.12}{1 + 37s} \cdot e^{-3 \cdot s} \quad (4)$$

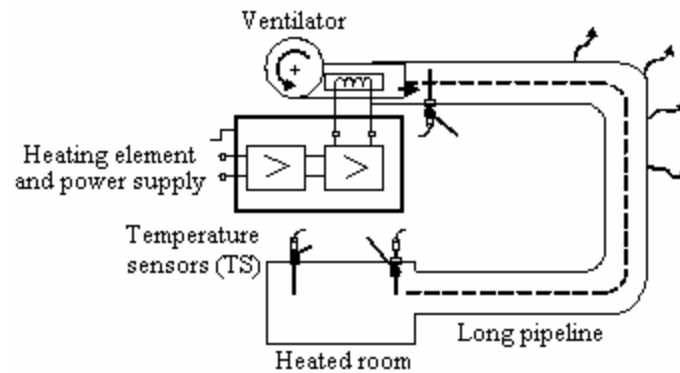

Figure 6  
 Laboratory model for a room, heated by long pipeline

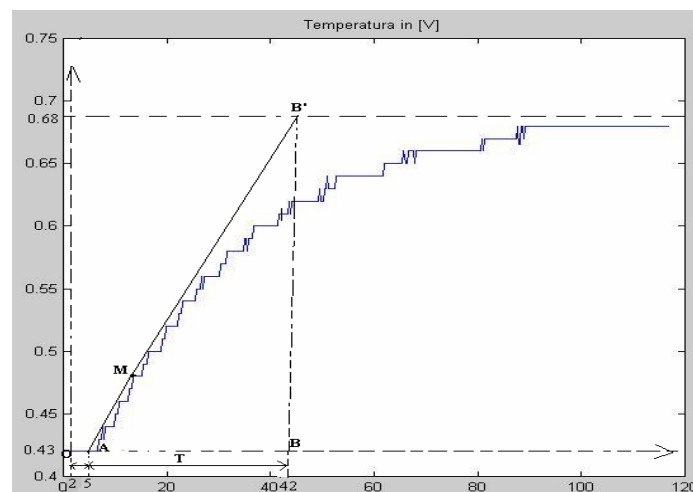

Figure 7  
 Example of experimental identification

The tuning methods applied - in continuous-time or in discrete-time (Ziegler-Nichols, Chien-Hrones-Reswick, Cohen-Coon or dead-beat in Dahlin's version) are implemented in dedicated controller modules. Snapshots from the user interfaces are presented and exemplified in Fig. 8 (a) and (b). The calculations concerning the parameters of the digital control algorithms are computer-assisted.

The control is ensured by means of the CoMax-ProTerm equipment [10] and software necessary for controlling the system, extended with several controllers.



The CoMax equipment is employed for controller implementation and transmission-reception of control signal and controlled output between computer and controlled plant. The program is coded in Visual C++.net 2003, the last version (at that time) of Visual Studio suite.



Figure 8

Implementation snapshots: process parameters and calculation of controller parameters (a), imposed CS performance indices (b)

The application 2 deals with one laboratory model of a floor-heated room, Fig. 9. The application is actual in the context of modern heating systems. One simplified mathematical modelling of the plant is based on (5) [11]:

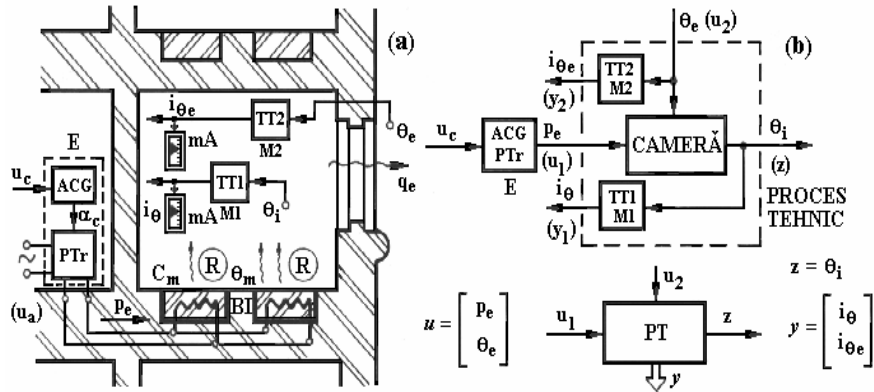

Figure 9

Functional (a) and informational (b) block diagrams for controlled plant 'floor-heating of a room' (text in Romanian)

$$\begin{aligned}
 C_p \dot{\theta}_p &= p_e - k_p (\theta_p - \theta_c), \\
 C_c \dot{\theta}_c &= k_p (\theta_p - \theta_c) - k_c (\theta_c - \theta_e), \\
 z &= \theta_c, \quad p_e = k_E u, \quad u_\theta = k_M \theta_c,
 \end{aligned} \tag{5}$$

where the index 'p' corresponds to the floor and the index 'c' to the room. The state-space mathematical model is derived on the basis of (5), then the block diagram is built and the PL2 (-DT) type transfer function is justified.

Next, this application is approached from two points of view:

- theoretical approach, where on the basis of a numerical example, individualized for teams consisting of 3 students, they have to determine based on linearized input-output static maps operating points, variations domains for the characteristic variables, gains, etc., that represent the support for the mentioned control solutions to be developed (open-loop control, PID, Smith predictor, polynomial structures of GPC);
- experimental approach performed on laboratory equipment (self-built in the Control Engineering Laboratory), the experiments concern firstly the block diagrams with PI(D) controllers and Smith predictors.

In case of predictive control [12], the GPC algorithm is converted into a polynomial 2-DOF structure (RST structure), Fig. 10 (a), where the plant is represented in a CARIMA type model:

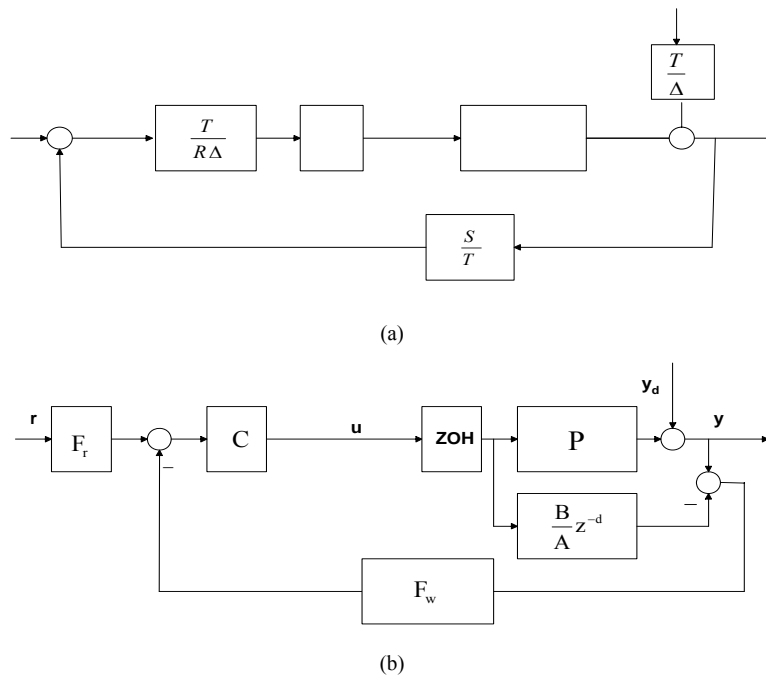

Figure 10  
 IMC structure of GPC

$$A(q^{-1})y(t) = z^{-d}B(q^{-1})u(t-1) + C(q^{-1})\frac{e(t)}{\Delta}, \quad (6)$$

$R(q)$ ,  $S(q)$ ,  $T(q)$  being polynomials in the backward shift operator. For having a plant model as (2) or (3), in many cases polynomial  $C(q^{-1})$  cannot be identified, therefore it is substituted with a polynomial  $T(q)$  that can be considered as a pre-filter or a fixed observer. Choosing  $T(q^{-1}) = 1$  for simplicity and solving the Diophantine equation, the final expressions of the polynomials  $R$ ,  $S$  and  $T$  will be:

$$R(q^{-1}) = \frac{T(q^{-1}) + q^{-1} \sum_{i=N_1}^{N_2} k_i I_i}{\sum_{i=N_1}^{N_2} k_i}, \quad S(q^{-1}) = \frac{\sum_{i=N_1}^{N_2} k_i F_i}{\sum_{i=N_1}^{N_2} k_i}, \quad T(q^{-1}) = 1, \quad (7)$$

where the polynomial  $T(q^{-1})$  is a free parameter, set according to development requirements,  $F_i$  and  $I_i$  are elements of the Diophantine equations. The RST polynomial structure is transformed into a 2-DOF IMC structure, as seen in Fig. 10 (b). Approaching step-by-step, the following results are obtained:

$$C(q^{-1}) = \frac{S(q^{-1})A(q^{-1})}{F_w(q^{-1})(R(q^{-1})\Delta A(q^{-1}) + S(q^{-1})B(q^{-1})q^{-d})}, \quad (8)$$

$$\frac{T(q^{-1})}{S(q^{-1})} = \frac{F_r(q^{-1})}{F_w(q^{-1})}.$$

The IMC structure is valid for stable plants only. The equivalences between the two structures are:

$$C(q^{-1}) = \frac{S(q^{-1})A(q^{-1})}{F_w(q^{-1})(R(q^{-1})\Delta A(q^{-1}) + S(q^{-1})B(q^{-1})q^{-d})}, \quad (9)$$

$$\frac{T(q^{-1})}{S(q^{-1})} = \frac{F_r(q^{-1})}{F_w(q^{-1})}.$$

The IMC structure is valid for stable plants only. The equivalences between the two structures are:

$$F_r = T, \quad F_w = S, \quad C_{IMC} = \frac{A}{R\Delta A + BSz^{-d}}. \quad (10)$$

The IMC structure has many advantages over conventional control which must be understood and accepted by the engineer. In the IMC structure, if there is no mismatch between the plant and the model, then actually open-loop control will be involved [13]. If there is mismatch between them, the closed-loop will work against it. In this structure an integrating effect is generated by the loop and the static error is brought to zero.

It is essential for the student to make conscious the significance of choosing the control structures, the algorithmic calculus and then to support a certain solution, comparative with other ones. The experimental testing will back up afterwards the results of theoretical approaches.

#### 4 Third Case Study: Position Control of an Inverted Pendulum System (Unstable Plant)

The inverted pendulum system (Fig. 11) is a widely used benchmark in CS development [14]. The vertical stationary positions of the pendulum (upright and down) are equilibrium positions when no force is being applied. The upright equilibrium point is unstable. The purpose of the inverted pendulum control algorithms is to apply a sequence of forces of constrained magnitude to the cart such that the pole starts to swing with an increasing amplitude and the cart does not override the ends of the rail. The pole is swung up to achieve a vicinity of its upright position. Once this has been accomplished, the controller is maintaining the pole vertical and is bringing the cart back to the centre of the rail. Therefore two independent control algorithms are implemented to achieve this purpose corresponding to two control problems (modes), the swing up one (SU) and the self-erecting (SE) or stabilizing one. The third problem is the crane one (C) and consists of ensuring the desired cart position while the pole remains in its vertical position. The nonlinear state-space model of controlled plant can be expressed in the following form [15]:

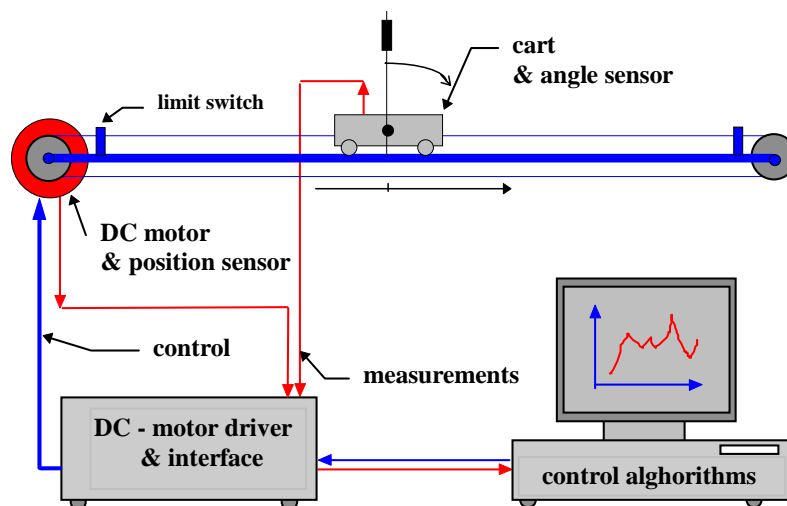

Figure 11  
Inverted pendulum system setup

$$\begin{aligned} \dot{x}_1 &= x_3, \\ \dot{x}_2 &= x_4, \\ \dot{x}_3 &= (a(u - f_c x_3 - \mu x_4^2 \sin x_2) + l \cos x_2 (\mu g \sin x_2 - f_p x_4)) \cdot \\ &\cdot (J + l \sin^2 x_2)^{-1}, \\ \dot{x}_4 &= (l \cos x_2 (u - f_c x_3 - \mu x_4^2 \sin x_2) + \mu g \sin x_2 - f_p x_4) (J + l \sin^2 x_2)^{-1}, \end{aligned} \quad (11)$$

where  $x_1$  is the cart position (distance from the centre of the rail),  $x_2$  is the angle between the upward vertical and the ray pointing at the centre of mass, measured counter-clockwise from the cart ( $x_2 = 0$  for the upright position of the pendulum),  $x_3$  is the cart velocity, and  $x_4$  is the pendulum angular velocity. The parameters in (11) can be calculated in terms of (12) where the control signal is bounded:

$$a = l^2 + \frac{J}{m_c + m_p}, \quad \mu = (m_c + m_p)l, \quad |F(t)| \leq M. \quad (12)$$

The CS structure is presented in Fig. 12. It points out the main part, the real-time Simulink diagram. So the laboratory activities in fuzzy control [2] are focused on gaining knowledge on implementing fuzzy controllers in Matlab by means of the Fuzzy Logic toolbox [16]. The following subjects are treated: implementation of membership functions, of linguistic variables and terms; implementation of rule bases and inference engines; setting the defuzzification methods; working with fis-type files; implementation of fuzzy controllers in Simulink diagrams. The real-time implementation technologies are known by the students from other courses.

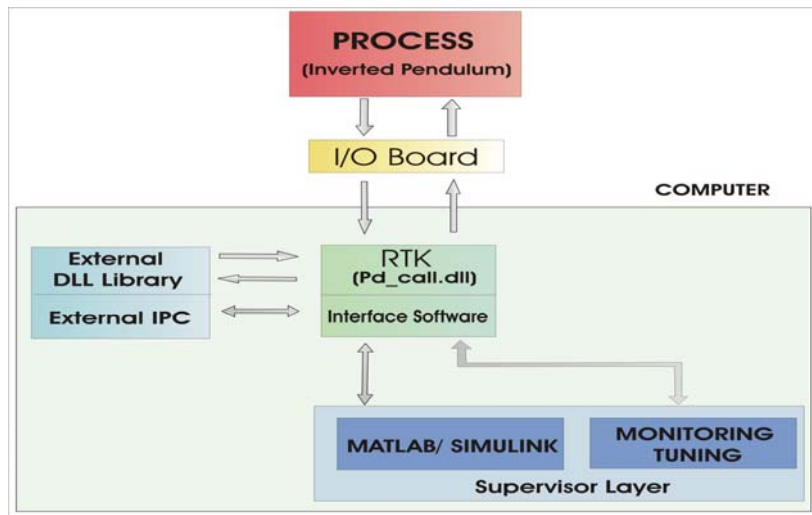

Figure 12  
 Control system structure

A new user interface has been built with our students (Fig. 13). It enables the easy experimentations and ensures a good flexibility.

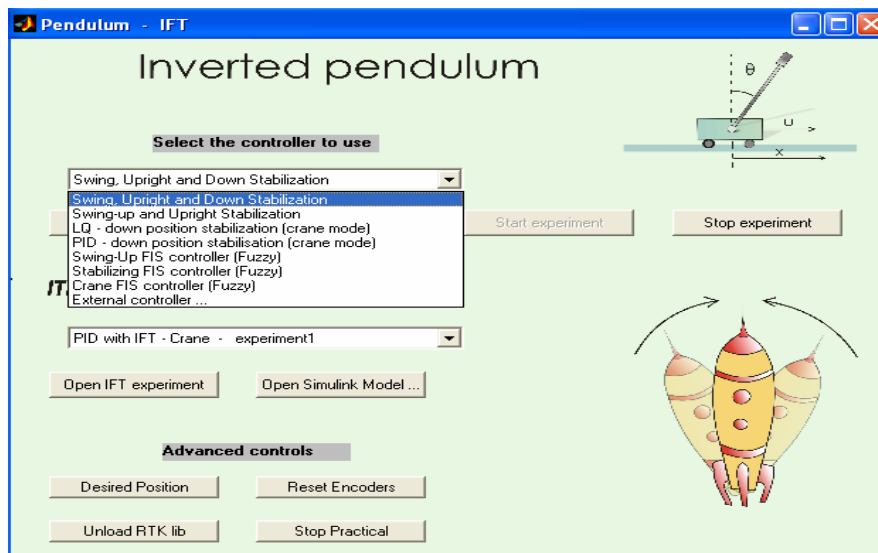

Figure 13  
User interface

Accepting the SE control problem, the real-time Simulink diagram is presented in Fig. 14, where FIS stands for Fuzzy Inference System. The fuzzy controller structure is illustrated in Fig. 15 (a), and some real-time experimental results in Fig. 15 (b). The laboratories are done individually in the first part when the knowledge on Fuzzy Logic Toolbox is needed. Next, they work in groups of 3 students to develop and implement the fuzzy controllers. The development is done starting with an initial conventional controller and applying the modal equivalence principle. The students have access to all source files that enable the development process.

## 5 Curricula Perspectives in the Framework of the Bologna Process

In this moment in the framework of the Bologna Process the Control Engineering Syllabus does not suffer major changes. At BSc level only a small reduction of the number of hours is involved and the practical application are approached more closely (see the content of this paper). At MSc level the weight of research & development activities will increase by finding the most generous solutions with

this respect. The fuzzy control syllabus has increased number of laboratory activity from 1.5 hours per week up to 2 hours. First this will permit to learn other implementation software dedicated to the implementation of fuzzy controllers; these controllers are already implemented in the Intelligent Control Systems Laboratory in controlling other equipment. Second this represents the basis to deal with more complex fuzzy controller structures to be treated at MSc level.

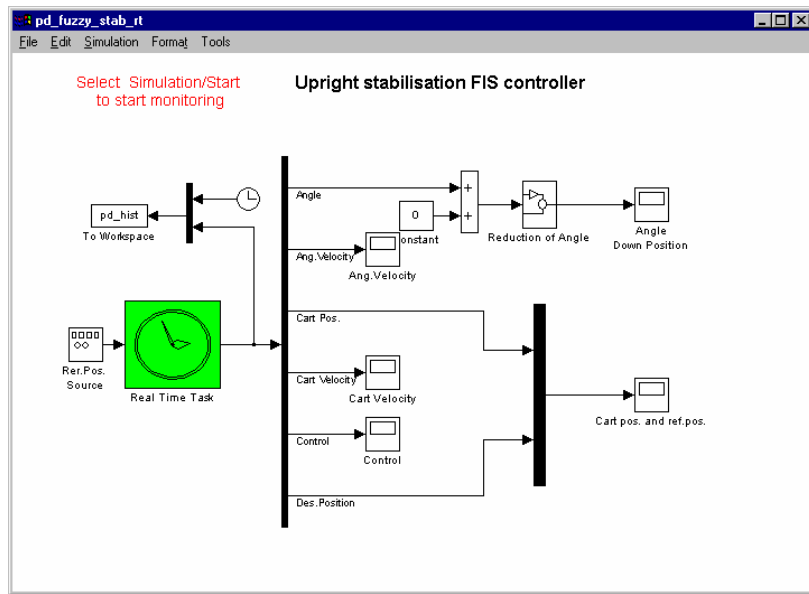

Figure 14  
 Real-time Simulink diagram

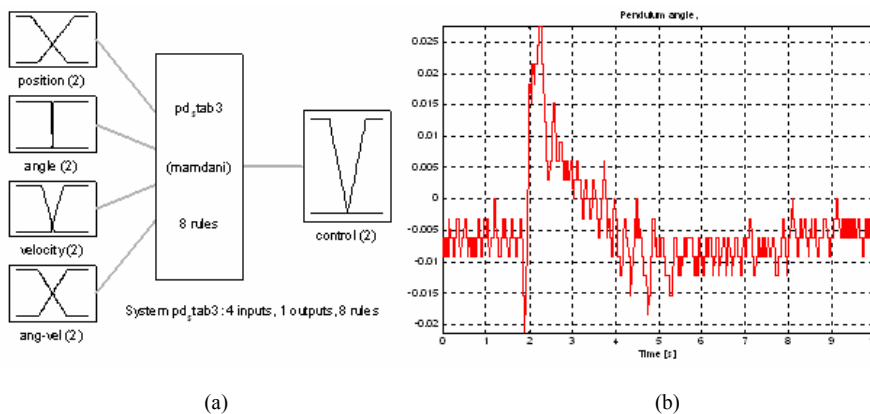

Figure 15  
 Fuzzy controller structure (a) and real-time experimental results (b)

### Conclusions

The paper presents conceptual aspects concerning the design, implementation and experimentation of advanced CSs meant for controlling the technological parameters – in particular, slow and rapid plants – of multifunctional laboratory equipment. In the presented manner to approach the laboratory activity the student should be put in the situation to analyze ‘completely’ developed control solutions and to decide on the opportunity of one solution or another one.

Due to the multiple aspects, which can be taken into consideration in the experimental part, the discussion on the final conclusions is done on classrooms with several groups of students. More complex studies, treating collateral aspects, are solved in the framework of the diploma theses, which are meant to provide by self-construction the equipment basis for experiments.

### Acknowledgement

The supports stemming from:

- the cooperation between Budapest Tech Polytechnical Institution and “Politehnica” University of Timisoara in the framework of the Hungarian-Romanian Intergovernmental S & T Cooperation Program No. 35, ID 17 (2006-2008),
- two CNCSIS grants (2006-2007) and (2007-2008),

are acknowledged.

### References

- [1] S. Preitl: Control Structure and Algorithms, Control Engineering, Lecture notes and laboratories in the curriculum of Automation and Applied Informatics area of specialization in the academic year 2004-2005, Faculty of Automation and Computers, “Politehnica” University of Timisoara, Timisoara, 2006
- [2] R.-E. Precup: Fuzzy Control Systems, Lecture notes and laboratories in the curriculum of Automation and Applied Informatics area of specialization in the academic year 2006-2007, Faculty of Automation and Computers, “Politehnica” University of Timisoara, Timisoara, 2007
- [3] Amira: DR300 Laboratory Setup Speed Control with Variable Load, AMIRA GmbH, Duisburg, 2000
- [4] K.-J. Åström, T. Hägglund: PID Controllers Theory: Design and Tuning, Instrument Society of America, Research Triangle Park, NC, 1995
- [5] S. Preitl, R.-E. Precup: An Extension of Tuning Relations after Symmetrical Optimum Method for PI and PID Controllers, in *Automatica*, 1999, Vol. 35, No. 10, pp. 1731-1736



- [6] Zs. Preitl: Improving Disturbance Rejection by Means of a Double Parameterization of the Symmetrical Optimum Method, in Scientific Bulletin of “Politehnica” University of Timișoara, Series Automation and Computers, 2005, Vol. 50 (64), No. 1-2, pp. 25-34
- [7] C. Brosilow, J. Babu: Techniques of Model-Based Control, Prentice Hall PTR, Upper Saddle River, NJ, 2002
- [8] A. O’Dwyer: Handbook of PI and PID Controller Tuning Rules, Imperial College Press, London, 2003
- [9] S. Preitl, R.-E. Precup, I.-B. Ursache, S. Gheju, Zs. Preitl: Methodical Aspects Concerning the Study of Control Solutions for Plant with Slow Response, in Scientific Bulletin of “Politehnica” University of Timisoara, Romania, Transactions on Automatic Control and Computer Science, 2004, Vol. 49 (63), No. 1, pp. 127-132
- [10] CoMax: CoMax-User’s Manual, Department of Automation and Systems Engineering, Faculty of Automation and Computers, Politehnica University of Bucharest, Bucharest, 2000 (in Romanian)
- [11] S. Preitl, R.-E. Precup: Introduction to Control Engineering, Editura Politehnica, Timisoara, 2001 (in Romanian)
- [12] Zs. Preitl, R. Bars, I. Vajk, R. Haber: Internal Model Representation for Generalized Predictive Control with Constraint Handling, in Proceedings of IEEE 4<sup>th</sup> International Conference on Intelligent Systems Design and Application ISDA 2004, Budapest, Hungary, 2004, pp. 681-685
- [13] E. F. Camacho, C. Bordons: Model Predictive Control, Springer Verlag, Berlin, 1999
- [14] Feedback: Inverted Pendulum System, Feedback Ltd., Crowborough, UK, 1998
- [15] A. Turnau, P. Gorczyca, W. Grega, K. Hajduk, K. Kolek, M. Pauluk, M. Rosól: Inverted Pendulum Getting Started, INTECO S-ka z o.o., Kraków, Poland, 1997
- [16] Matlab: Fuzzy Logic Toolbox User’s Guide, The MathWorks, Inc., Natick, Ma, 1998