

New Developments on the HUNVEYOR-4 Educational Space Probe

György Hudoba, Zoltán Balogh

Institute of Computer Engineering, Kandó Kálmán Faculty of Electrical
Engineering, Budapest Tech
Budai út 45, H-8000 Székesfehérvár, Hungary
hudoba.gyorgy@szgti.bmf.hu

Szaniszló Bérczi

Dept. of G. Physics, Eötvös Loránd University
Pázmány Péter sétány 1/A, H-1117 Budapest, Hungary

Abstract: Building HUNVEYOR-4 brings a fresh air into the education at the Institute of Computer Engineering, Kandó Kálmán Faculty of Electrical Engineering, Budapest Tech located in Székesfehérvár. The project, started in the academic year 2001-2002, is giving the students an opportunity to build different sensors, instruments, develop sophisticated measurements and methods, hardware and software components and solutions in order to exercise their engineering skills.[1,2,3,4]



1 Introduction

The first version of the HUNVEYOR-4 had the following structure by design:

All the input and output devices were connected to the probe through standard (serial and parallel) ports of the motherboard (see *Fig. 1.*). For example, four output bits of the printer port were used for controlling the individual coils of the camera stepping motor, and one input line (ACK) for reporting back the null-position of the camera, and so on. Our educational space probe has reached its limits, thus there is no more room for new sensors or other devices (e.g. manipulators). On the other side, both the ‘Control Unit’ and the ‘Probe Control Unit’ were implemented on the same computer, which is located on the probe. [4, 5]

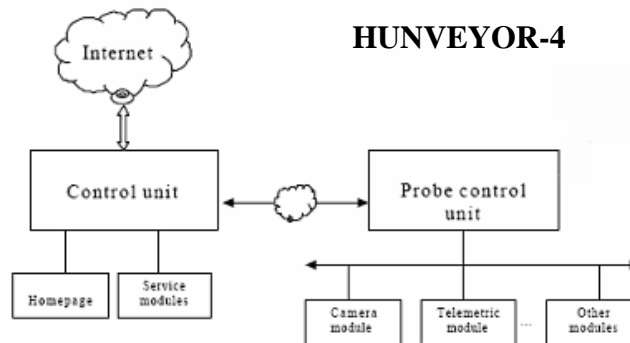

Figure 1

The block diagram of the first version

This solution has both advantages and disadvantages.

Advantages:

- all information is collected in the same place
- easy maintenance and update
- no need for a ‘Control Unit’ in case of road-shows and field measurements

Disadvantages:

- limited storage capacity (on the Flash-drive) for the
 - home page and documentation
 - data base (for the administration and collected data)
- low level of security

Last year we redesigned the system hardware as well as the software.

According to the new concept

- we designed a unified communication for the device units,
- the sensors and devices are chained up to an I²C bus,
- we designed a master device called Device Control Unit (DCU) which serves as an interface between the Probe Control Unit and the individual devices.

As a result, this new structure allows a virtually endless expansion of the system with new sensors and other devices, each having an individual identifier (address).

Regarding the software we have

- separated the ‘Terrestrial Control Unit’ (TCU) from the ‘Probe Control Unit’ (PCU), and the TCU was moved to a separate computer,
- engineered a communication method using XML-RPC protocol,
- redesigned the data base,
- rebuilt the user interface.

The new solution detailed above has many advantages (e.g. close to unlimited storage space, increased security and so on), but has a big disadvantage. In case we cannot establish a cabled or wireless connection with the server running the ‘Terrestrial Control Unit’, we need a dedicated computer with a mirrored TCU for controlling the probe. On the field this is a potential source of some difficulties. Weighing the different possibilities, despite of the disadvantages mentioned above, we decided to rebuild the probe, keeping in mind that our aim is to give the students an opportunity to exercise their engineering skills. The redesigned space probe we call ‘HUNVEYOR-4b’.

2 The HUNVEYOR-4b

According to the new design, the user can not reach the probe directly anymore, only the Terrestrial Control Unit (see *Fig. 2*). The requests coming from the user’s browser will be transformed to XML-RPC calls and transferred to the Probe Control Unit. The XML-RPC server interprets the calls and converts them to lower level commands. These commands will control the individual units. However the server cannot see these devices directly. The commands will pass to the I/O Communication Module which will send the data to the Device Control Unit using USB controller. Finally the DCU forwards the data to the selected device via I²C. [6, 7, 8]

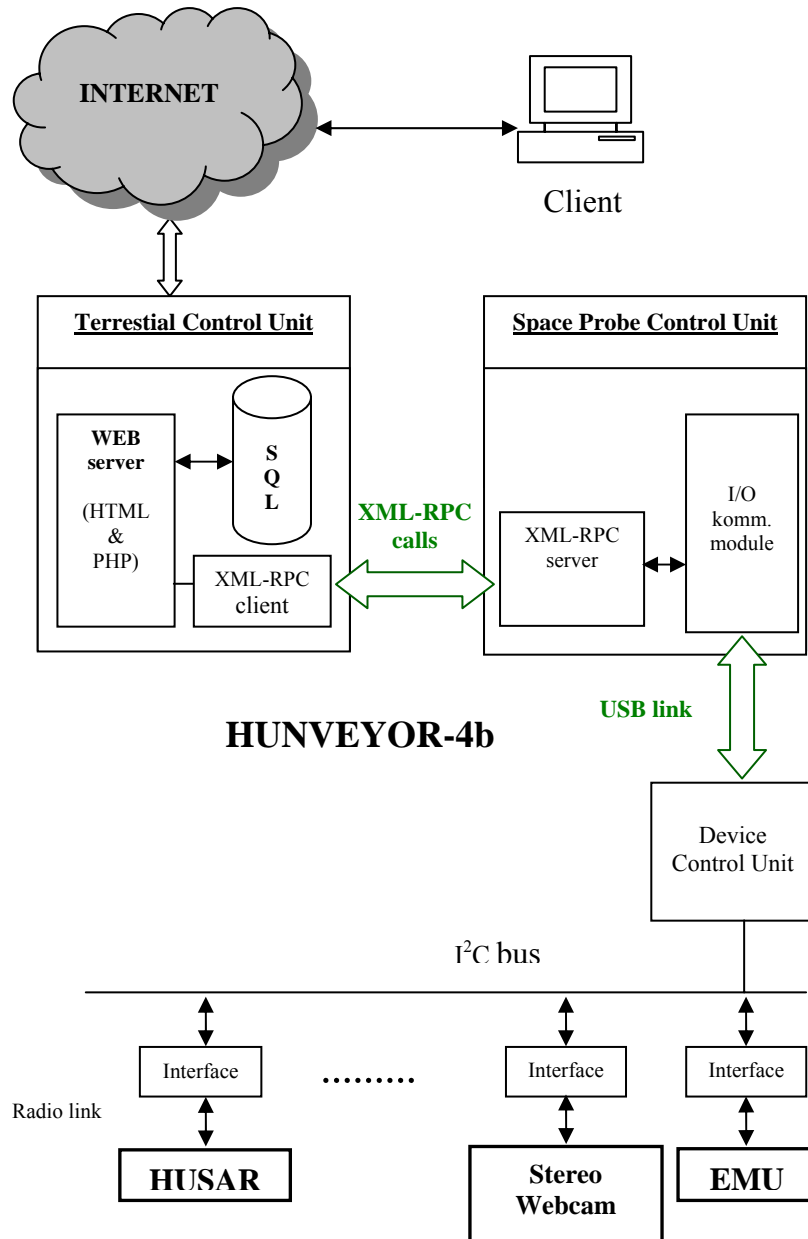

Figure 2
 The block diagram of the HUNVEYOR-4b

2.1 The Device Control Unit

The primary role of the DCU is to convert the data stream between the USB and the I²C bus. In addition it serves as a USB1 hub for the two cameras, a power distributor for the device units, and eight bit general purpose lines for future needs, such as switching the light on and off at night time for the imaging camera and so on.

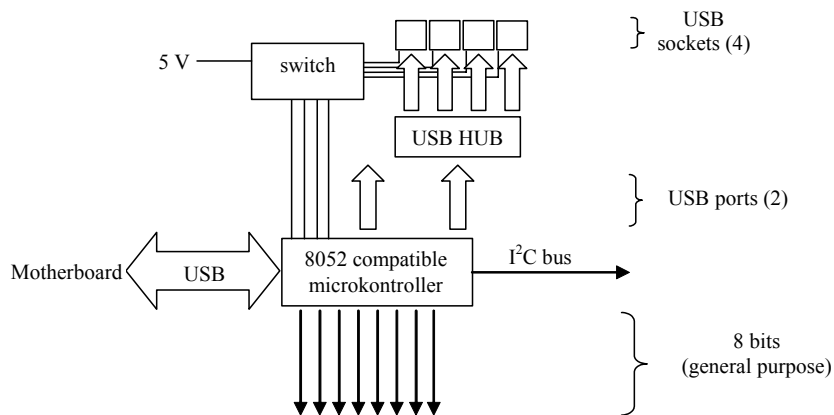

Figure 3

The block diagram of the Device Control Unit

The Universal Serial Bus (USB) is a serial bus standard to interface devices. A USB system has an asymmetric design, consisting of a host controller and multiple daisy-chained devices. Additional USB hubs may be included in the chain as can be seen in Fig. 3, allowing branching into a tree structure, subject to a limit of 5 levels of branching per controller.

The I²C (Inter-Integrated Circuit) is a multi-master serial computer bus invented by Philips that is used to attach low-speed peripherals to a motherboard or embedded systems. I²C uses only two bidirectional open-collector lines, serial data (SDA) and serial clock (SCL), pulled up with resistors. The bus is a multi-master bus which means any number of master nodes can be present. Additionally, a master can also be a slave, and vice-versa.

2.2 The XML-RPC Calls

XML-RPC is a remote procedure call protocol which uses XML to encode its calls and HTTP as a transport mechanism. It is a simple protocol, defining only a handful of data types and commands.

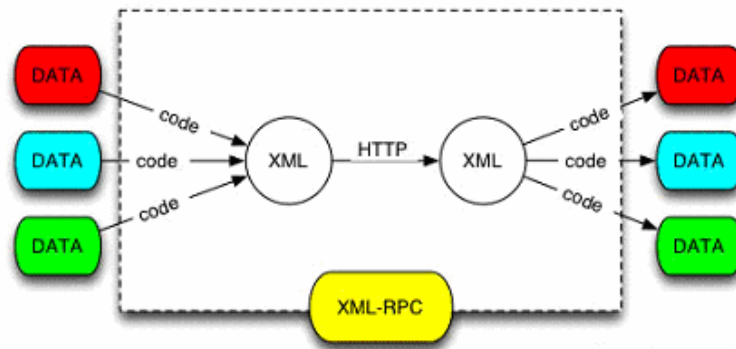

Figure 5
The XML-RPC

Because XML is platform independent, and HTTP is a well supported protocol, using XML-RPC was a reasonable choice. In the communication between the TCU and the PCU we use HTTPS, the secure version of the HTTP protocol.

Currently we developed XML-RPC calls (or methods) for the following devices:

2.2.1 Web Camera Module

- initialize
- acquire picture
- set brightness and contrast
- set camera position

2.2.2 Weather Station

- read temperature
- read light
- set wind speed measurement parameters and start
- read wind speed
- read wind direction
- set radiation detector parameters and start
- read radiation value

2.2.3 HUSAR (HUNGarian Surface Analyzer Rower)

- set engine parameters
- read engine status
- rower light ON/OFF
- read rower light status
- read temperature
- read light
- set LED spectrometer parameters and start
- read spectrometer status and data

2.3 The Standardized Format of the Commands

ADDR	LG	DI	RESP	CMD	DATA
8 bits	8 bits	4 bits	1 bit	3 bits	

where:

- ADD - address of the selected unit
- LG - Length of the command starting from DI
- DI - Device Identifier
- RESP - if 0, then listen only, if 1, then response required
- CMD - command code
- DATA - Data field. (the number of data bytes can be derived from LG)

2.3.1 Devices

- DI = 0 - for each device
- DI = 1 - Weather Station
- DI = 2 - WebCameara platform
- DI = 3 - HUSAR

2.3.2 Command Codes

- *CMD = 000* - *reset*
- *CMD = 001* - *setup*

- *CMD = 010* - *read status*
- *CMD = 011* - *data read*
- *CMD = 100* - *emergency stop*
- *CMD = 110* - *wake up*
- *CMD = 111* - *standby*

2.4 The Terrestrial Control Unit

We redesigned and rebuilt the communication module including the database as well. The communication module or web server runs no longer on the probe but on a separate PC. The new design uses cascading style sheets and eye popping flash animations. For the data base engine we use PostgreSQL. The main concept of login, time reservation, controlling the probe, news or forums are more or less similar to the first version, but the database structure and its programming code have been completely rebuilt.

Summary

Last year we redesigned the HUNVEYOR-4. With the new hardware solution we can add significantly more sensors or other devices than before. We separated the 'Terrestrial Control Unit' from the 'Probe Control Unit'. The 'Terrestrial Control Unit' was moved to a separate computer. The two Unit communicate with each other using XML-RPC via secure version of the HTTP protocol. We completely rebuilt the user interface and the data base. The software is in more advanced state than the hardware. We gave our students many opportunities to exercise their engineering skills. The work has not finished yet, further upgrades (e.g. using FPAA's) are planned. [8, 9, 10, 11]

References

- [1] Sz. Bérczi, V. Cech, S. Hegyi, T. Borbola, T. Diósy, Z. Köllő, Sz. Tóth: Planetary Geology Education via Construction of a Planetary Lander (1998), LPSC XXIX, #1267, LPI Houston
- [2] Sz. Bérczi, B. Drommer, V. Cech, S. Hegyi, J. Herbert, Sz. Tóth, T. Diósy, F. Roskó, T. Borbola: New Programs with the Hunveyor Experimental Planetary Lander in the Universities and High Schools in Hungary (1999), LPSC XXX, #1332, LPI Houston
- [3] Sz. Bérczi, S. Kabai, S. Hegyi, V. Cech, B. Drommer, T. Földi, A. Fröhlich, G. Gévay: TUTOR on the Moon: A Discovery Type Multiple Lunar Probe (Improved Surveyors) Constructing and Research Program for Universities (1999), LPSC XXX, #1037, LPI Houston
- [4] Hudoba, Balogh, Safar, Berczi: Constructing HUNVEYOR-4, the Educational Space Probe, Symposium on Applied Machine Intelligence,

- Jan. 20-21, 2006, Herl'any, Slovakia, SAMI 2006 Proceedings, ISBN 963 7154 442
- [5] Hudoba, Gy., Sasvári G., Kerese P., Kiss Sz., Bérczi Sz.: Hunveyor-4 Construction at Kandó Kálmán Engineering Faculty of Budapest Polytechnic, Székesfehérvár, Hungary (2003), LPSC XXXIV, #1543, LPI, Houston
- [6] Balogh Zoltán: A Hunveyor-4 kommunikációs modulja, diplomamunka, 2006
- [7] Balogh Zoltán, Hudoba György: Hunveyor-4 kísérleti űrszonda kommunikációs rendszere, IKT 2006, Dunaújváros, 2006. okt. 17.
- [8] Nagy Attila: USB sín és alkalmazása a Hunveyor-4 projectben, diplomamunka, 2006
- [9] Szikra I., Ferenczi Gy., Varga T., Darányi I., Hudoba Gy., Földi T., Hegyi S., Bérczi Sz. (2006): A New Form of Space Science Education: Preparations for Phoenix Lander Mission Simulations by Hunveyor in Terrestrial Conditions. XXXVII LPSC, #1169
- [10] Györök György: Self Configuration Analog Circuit by FPAA, 4th Slovakian-Hungarian Joint Symposium on Applied Machine Intelligence, January 20-21, 2006, Herlany, Slovakia, ISBN 963 7154 44 4, pp. 508-516
- [11] Györök György: Reconfigurable Security Sensor by CCD Camera, 6th International Symposium of Hungarian Researches on Computational Intelligence, November 18-19, 2005, Buadapest, ISBN 963 7154 43 4, pp. 585-588