

Adjusting Process Parametres Using Intelligent Transducers and DAQ Boards

Mădălin Ștefan Vlad, Valentin Sgârciu

Faculty of Automatic Control and Computers
University "POLITEHNICA" of Bucharest,
E-mail: madalinv@ac.pub.ro, vsгарciu@aii.pub.ro

Abstract: *This paper proves the concept of remote control of sensors, for automated monitoring of industrial processes. Using National Instrument LabVIEW framework, we realized an application that monitor/command using the same server, different industrial processes.*

Keywords: *monitoring, remote command, remote control, DataSocket communication*

I INTRODUCTION

Technological process supervision assumes acquisition, processing and returning the commands for a big number of parameters. At the same time, it is necessary to monitor the investigated parameters, because the history is needed in guaranteeing the performances, but also establishing the causes which lead to malfunctions. Communication technologies and we refer here to Internet, which is mainly spread, allow data, acquired from long distances, to be concentrated in high performance servers. In the same time, following the temporal evolution of acquired parameters can be done from any computer, connected to Internet. This issue is suited both in technological processes, but also in education process, where a laboratory with high performance acquisition equipments and an Internet connection can be used by other laboratories less equipped.

This paper is focused on a solution of

data acquisition/distribution, using Lab VIEW framework, designated for long distance learning.

II WHY DATA ACQUISITION THROUGH INTERNET

In many of industrial processes, it is preferred the control at a distance of the equipments based on the received parameters. Sometimes, this process is absolutely necessary because of some high risk elements, or because of the conditions that do not allow the user to access it. As an example, one can mention the atomic piles where because of the high degree of radiations, the watch and control of the parameters must be done at a distance. Another example can be the watch of the furnaces, especially in the foundry works where because of the high temperatures, the user cannot physically stay in those areas. More than this, an advantage of the watch/ control at a distance is the possibility to watch more over than one equipment with a single

acquisition server. This aspect allows the taking over of the data from more sensors connected to various industrial equipments and also the transmission of the controls to them. The process can be developed from more than one host in the same time. Thus, there can be a client host that commands through Internet the parameters' modification of an installation, relying on a pressure sensor, while another client modifies the working characteristics of a thermal system, both sensors being connected to the same server.

To sum up, one can say that the advantages of control at a distance of the industrial equipment, relying on the watch/control of the parameters are:

- people should not have to work in the risk areas,
- the possibility to control more than one equipment in the same time from different hosts,
- the possibility to watch from a larger number of stations, without extra investments. It should be mentioned that the control of a sensor can be done by a single terminal, while the watch can be developed from many such terminals,
- the possibility of making some statistics in real time of the equipment's working. This can be done even by the management department of a company.

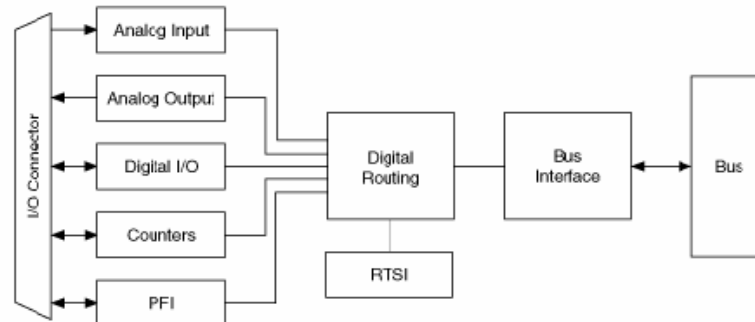

Figure 1
The principle scheme of the multifunctional board NI PCI-6014E

III NECESSARY HARDWARE RESOURCE FOR DATA ACQUISITION

The acquisition board is the key hardware component of the watch/control system. For our application we use a multifunctional board of analogs and numerical inputs-outputs from National Instrument –NI PCI-6014E. The principle scheme is shown in Figure 1, with short comments about its components.

I/O Connector – the connector to which the inputs and outputs from real world are brought up; the connector – with the pins configuration as shown in Figure 2- is prolonged through a ribbon cable next to a connection board where– through screw terminals – electrical links with real world are made.

Analog Input – analogical inputs block; its components are: the analogical multiplexer MUX, the

instrumental amplifier NI-PGIA with programmable amplification factor, the numerical-analogical converter ADC, the temporary memory for numerical equivalents of input signals AI FIFO and the trigger modes for input signals Analog Trigger.

Analog Output – the analogical outputs block; its components are: two numerical-analogical converters (DAC0 and DAC1) and a memory (AO FIFO) where the numerical equivalents of analogical output signals are brought, as well as the necessary controls for choosing the working domain and the polarity of the output tension.

Digital I/O –numerical inputs/outputs block composed of 8 pins for general usage that can be individually configured – through software- as numerical inputs, respective numerical outputs.

Counters –contains two counters of 24 bits, each one having two inputs (Source and Gate), one output (Out) and two software registers capable of different operations.

PFI (Programmable Function Interface) –contains 10 connections with the outside of the board through which one can collect temporary signals from outside and can generate different kinds of internal board's signals, inclusively the signals in relation with the operation mod for the two counters of 24 bits.

Digital Routing – contains all the circuits which manage the data flow between PC's pipe-line and the acquisition subsystems (analogical and digital inputs/outputs, counters).The numeric routing circuits use FIFO

memory in each subsystem to ensure an efficient flow of data. Also, through these circuits pass temporal and control signals which synchronize the acquisition.

AI 8	34	68	AI 0
AI 1	33	67	AI GND
AI GND	32	66	AI 9
AI 10	31	65	AI 2
AI 3	30	64	AI GND
AI GND	29	63	AI 11
AI 4	28	62	AI SENSE
AI GND	27	61	AI 12
AI 13	26	60	AI 5
AI 6	25	59	AI GND
AI GND	24	58	AI 14
AI 15	23	57	AI 7
AO 0 ¹	22	56	AI GND
AO 1 ¹	21	55	AO GND
AO EXT REF ¹	20	54	AO GND
P0.4	19	53	D GND
D GND	18	52	P0.0
P0.1	17	51	P0.5
P0.6	16	50	D GND
D GND	15	49	P0.2
+5 V	14	48	P0.7
D GND	13	47	P0.3
D GND	12	46	AI HOLD COMP
PFI 0/AI START TRIG	11	45	EXT STROBE
PFI 1/AI REF TRIG	10	44	D GND
D GND	9	43	PFI 2/AI CONV CLK
+5 V	8	42	PFI 3/CTR 1 SRC
D GND	7	41	PFI 4/CTR 1 GATE
PFI 5/AO SAMP CLK	6	40	CTR 1 OUT
PFI 6/AO START TRIG	5	39	D GND
D GND	4	38	PFI 7/AI SAMP CLK
PFI 9/CTR 0 GATE	3	37	PFI 8/CTR 0 SRC
CTR 0 OUT	2	36	D GND
FREQ OUT	1	35	D GND

Figure 2

External connection of the NI PCI-6014E board

RTSI (Real-Time System Integration Bus) – an additional pipe-line through which you can achieve synchronization for specific measuring functions, when there are more than one acquisition board installed on the same PC, making use of the same time events.

Bus Interface – contains the hardware components through which the acquisition board connects to the PC's pipe-line, also it requires a driver which is included in the product.

facilities recommended by its producer National Instruments. The monitoring and command configuration is installed on a local workspace, and the access to the

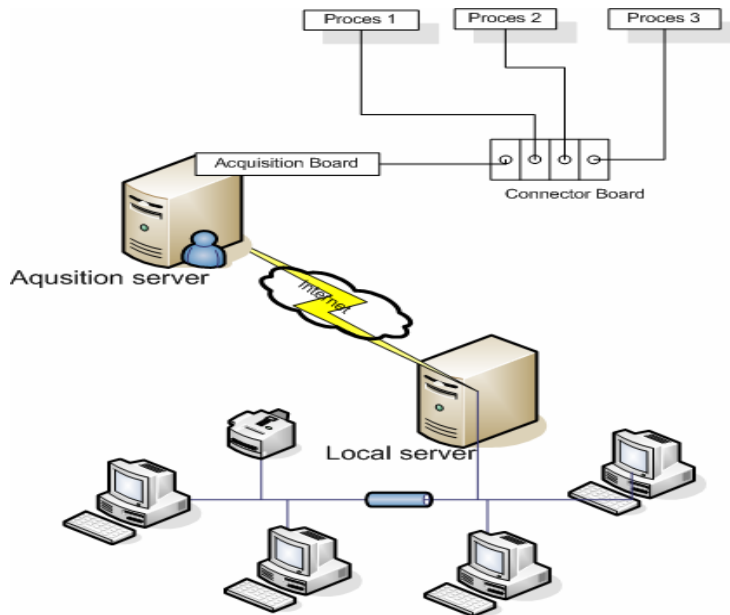

Figure 3
Application Structure

IV ACQUISITION SYSTEM

The structure of acquisition /distribution application is presented in Figure 3. At the level of the processes, which are constituted of measuring parameters like: temperature, speed, distance, pressure, you can find an application server where there are installed the programs of acquisition and control, as well as the Internet communication ones.

For compatibility Lab VIEW 6.1 is installed as well as at the level of the application server, but also at the workspaces PL1... PL4, with the

application server is done through an internet connection, which has a password. The system administrator can change the password each time he feels that the actions made from an outside connection don't match with the ones specified for them.

The remote controlled processes cover a large area of sensors, with output a continuous current unified signal, and also in frequency of impulses.

The acquisition board NI-PCI-6014E allows the measuring of continuous tension voltages and TTL numeric signals, while the commands could be analog or TTL numeric.

V THE APPLICATION FOR TEMPERATURE MONITORING

Before the board is being introduced into the PC, one should install the NI-DAQ 7.x software that is delivered with the board by National Instruments. At the installation, one should select the newest versions of drivers, the application server as well as the help files. After installing the software, one can introduce the board NI PCI-6014E on the PC bus, and the

Windows platform will recognize the new hardware.

If it is necessary, the next step will consist in setting-up the device. After that, the test runs from the panel through which the board's functionality is being demonstrated, respective its capacity to acquire and generate signals. The test passing assures the user that he can develop his own applications according to the proposed goal.

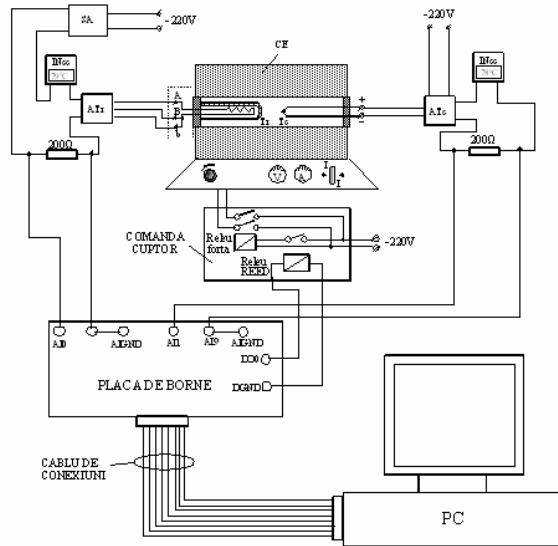

Figure 4

The temperature acquisition and bi-positional command of the heating oven layout schematic

Part of application's goal is to acquire two analogical signals provided by the thermocouples sensors adaptors, respective thermo resistor and also the generating of a stop command for the warming element (oven) when a superior preset temperature limit is reached. Also, when the oven temperature reaches a fixed inferior limit, the heating process is restarted

which means that goal is to obtain a bi-positional temperature regulation. The assembly layout can be seen in Figure 3 where:

- **CE**- electric element (heater) for generating the heating temperature of the two thermo elements (thermocouple and thermo resistor)

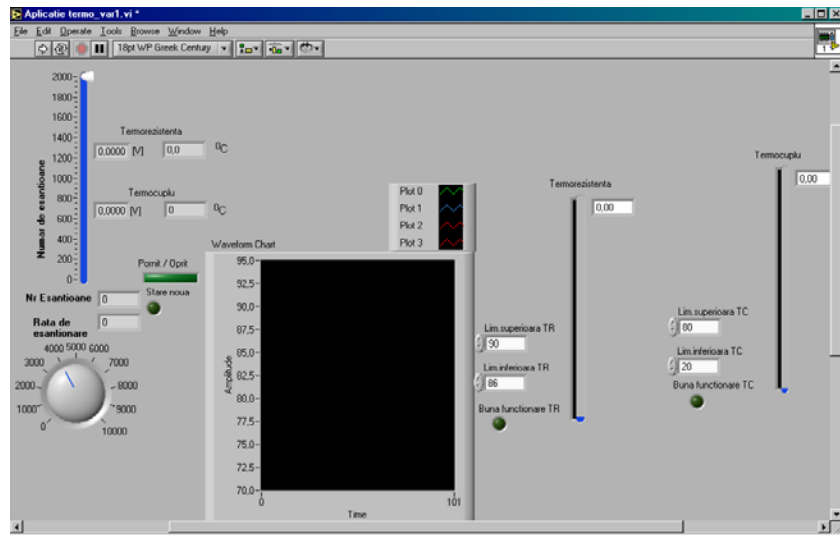

Figure 5

Front panel of the monitoring and controlling the temperature between two limits application

- **Atr, Atc** -adaptors for thermo resistor and thermocouple
- **INcc** –numeric indicators for unified signals (000 for 4 mA, respective 999 for 20mA)

PC-computer with the multifunctional NIPCI-6014E board installed; using a flexible cable the extern connections – in conformity with the specification from Figure 2 – are bought to a terminals board.

As we presented earlier, the two sensors have the role to maintain the oven temperature between certain limits. Because of the constructive differences between these, one of them will effectively command the starting/stopping of the oven, while the second will have a protection role in the installation. The second sensor will stay between the limits, and in case of the first sensor's malfunction (which represents a bigger sensibility) the second sensor will take over the obligations of the first to command the

heating element. The logic of the application is based on RS two-state.

The application's panel can be seen in Figs. 5 and 6 the corresponding diagram. On the panel one can observe that that signal acquisition can be made at various sampling rates and also on different numbers of samples, both aspects can be seen by running the application on continuous mode.

In addition, both for the thermo resistor and for the thermocouple, indicators have been provided for showing both the value for the converted voltage and their correspondence in °C. When running the application we simultaneously obtain the two indications for each element.

In the right hand side of the panel, we have provided the commands for setting the optimum working values for each thermo element. As long as the current value is outside of the fixed values the bare graph indicator will be

doubled by a red colored line, as long as the current value is between the fixed values this bar becomes blue (the same with the current value).

The evolution of the acquired signals and the optimum working values (the application only considers the signal from the thermo resistor for generating commands), can be permanently visualized on the wave graph situated in the center of the panel.

While running the applications the user will observe the assembly's evolution in concordance with the imposed specifications, identifying ways of implementation the functional sub entities on the diagram and correspondingly on the panel.

VI THE COMMUNICATION MODULE

- The application has two main parts:
- the part of data acquisition and data processing;
 - the part of communication.

The module responsible for communication was developed using NI DataSocket Server-Client

communication. In order for the application to work, the Data Server application must be running.

The server module of the application writes data in the server, and then every client can read the data. The client which have rights of issuing commands to the server, can also write data in the server. Also, the server application can read command data from the server and apply it to the sensors. Below is presented the module responsible for writing data into the DataSocket server.

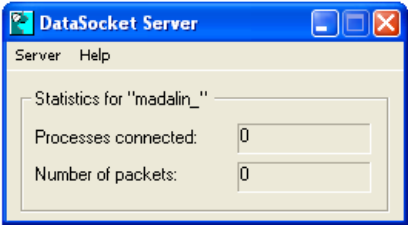

Figure 6
The DataSocket Server

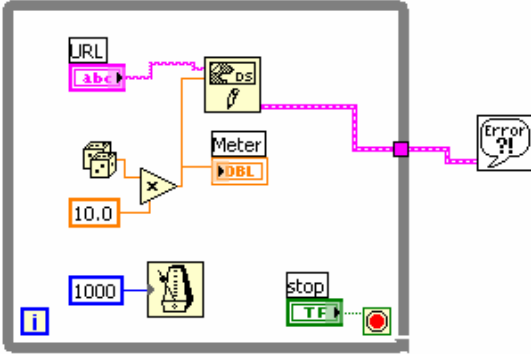

Figure 7
The module the writes data in the DataSocket Server

Conclusions

The application was designed and developed to prove a couple of concepts about the data acquisition in general and some notions about the possibility of adding remote controlling/monitoring. This has a teaching purpose: it is being used for a series of experiments between several laboratories, at the moment. From one point of view one can process the experimental data gathered from a real process, but one can also see the result of one remote command sent to industrial equipment in the real time. The main part is, as we mentioned earlier, the server with the data acquisition board. As main topic of this paper we presented the process of remote controlling of the temperature of a precinct, but the server can deal with more than one application in the same time. Thus it can monitor parameters provided by 16 sensors and it can lead till four industrial equipments in the same time, using the data acquisition board NI PCI 6014E.

References

- [1] Bajic, E.: Holonic Manufacturing with Intelligent Objects, 5th IFIP International Conference, Cancun, Mexico, 2002
- [2] Wong C. Y., D. McFarlane, A. Ahmad Zaharudin, V. Agarwal: The Intelligent Product Driven Supply Chain, in Proc. IEEE International Conference on Systems, Man and Cybernetics, Hammamet, Tunisia, 2002